

TSE SERIES

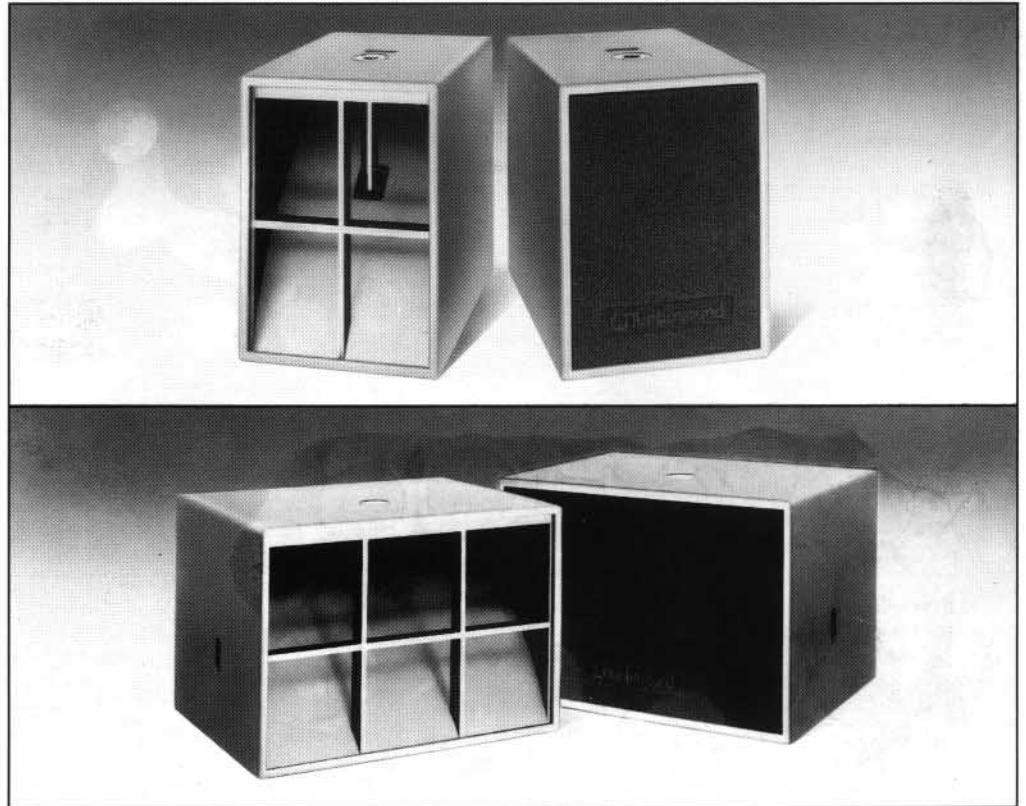

TSE-118/218

LOW-FREQUENCY LOUDSPEAKER ENCLOSURES

The TSE-118 and TSE-218 are low-frequency, professional loudspeaker enclosures incorporating Turbosound's patented loading principles. They are modules designed to cover low frequencies (40 - 300Hz) in primary sound-reinforcement systems and form part of a series of complementary enclosures principally intended for sound contracting.

The enclosures incorporate the TurboBass™ device, which is a unique design, covered worldwide by Principle Patents. The device

Turbosound engineers to construct low-frequency enclosures which produce high sound-pressure levels with very low distortion and power compression. The TSE-118 and TSE-218 enclosures both operate without depending on compensating electronics to match or correct for component disparities.

A range of load-certified flying and mounting hardware is available as standard items. This allows simple installation and orientation of the enclosures; from a single enclosure up to a 360°

FEATURES

Unprecedented Bass Response
 Compact Enclosure Design
 Universal Flying & Mounting System

employs a high-velocity partial horn-loading technique, giving precise cone control and providing remarkable levels of bass projection from compact enclosures.

These enclosures are capable of outstanding electrical to acoustic power conversion (TSE-118: 102dB at 1W/1m; TSE-218: 105dB at 1W/1m) and can develop peak sound pressure levels of 130dB for the TSE-118 and 136dB for the TSE-218. It is the result of meticulous study which compelled Turbosound to re-evaluate established design parameters. The unique developments which followed have enabled

APPLICATIONS

Sound Contracting
 Main PA Systems
 Discotheques and Clubs

point-source cluster (TSE-118 only). Refer to the Flying and Lifting section for detailed information.

The TSE Series comprises several fully compatible modular enclosures. Each one is designed to address a specific sound reinforcement situation and to defeat the acoustic problems presented to it. The result: a dedicated system producing natural sound from an unusually compact range of enclosures.

Please refer to the Product Range Catalogue and individual Engineering Information sheets for further information.

TECHNICAL SPECIFICATIONS

	TSE-118	TSE-218
Dimensions¹	685 mmH x 503 mmW x 721 mmD (26¾"H x 19¾"W x 28¼"D)	685 mmH x 988 mmW x 721 mmD (26¾"H x 38¾"W x 28¼"D)
Weight	40.25 kg (90 lbs)	73 kg (160 lbs)
Components	1 x 457mm (18") LF driver on a TurboBass™ device	2 x 457mm (18") LF drivers on 2 TurboBass™ devices
Frequency Response²	55 - 450 Hz ± 4dB (Recommended operational range 45 - 300 Hz)	50 - 450 Hz ± 4dB (Recommended operational range 40 - 300 Hz)
Power Handling	300W RMS (600W program)	600W RMS (1200W program)
Sensitivity³	102dB, 1Watt/ 1meter (Average 60 - 300Hz)	105dB, 1Watt/ 1meter (Average 60 - 300Hz)
Maximum SPL	123dB (Continuous) ⁴ 130dB (Peak) ⁵	129dB (Continuous) ⁴ 136dB (Peak) ⁵
Power Compression		
@ -10dB rated power	0.3dB (30W)	0.3dB (60W)
@ -3dB rated power	1.5dB (150W)	1.5dB (300W)
@ rated power	3.0dB	3.0dB
Crossover	Active: Recommended points 80 - 250Hz, 24db/octave, Linkwitz-Riley (depending on application).	Active: Recommended points 80 - 250Hz, 24db/octave, Linkwitz-Riley (depending on application).
Impedance	8 ohms nominal	4 ohms nominal
Polarity	Positive voltage applied to pin 2 of the XLR connector causes forward movement of the cone.	Positive voltage applied to pin 2 of the XLR connector causes forward movement of the cones.
Construction	15mm birch ply throughout; rebated, screwed and glued. Finished in TurboBlue semi-matt paint ⁶ . Two recessed carrying handles. Four heavy-duty wheels.	15mm birch ply throughout; rebated, screwed and glued. Finished in TurboBlue semi-matt paint ⁶ . Two recessed carrying handles. Four heavy-duty wheels.
Grille	25mm (1") thick 30 PPI fully reticulated foam	25mm (1") thick 30 PPI fully reticulated foam
Connectors	3 pin XLR; 1 male, 1 female Wired pin 1 -ve; pin 2 +ve; pin 3 N/C	3 pin XLR; 1 male, 1 female Wired pin 1 -ve; pin 2 +ve; pin 3 N/C
	PA-151 Pole kit assembly FF-118 Flying frame	PA-151 Pole kit assembly
Spares	FG-118 Replacement foam grille LS-1802 18" LF loudspeaker RC-1802 Recone kit for LS-1802 W-4 Wheel kit ASC-203 Aerosol can: TurboBlue	FG-218 Replacement foam grille LS-1802 18" LF loudspeaker RC-1802 Recone kit for LS-1802 W-4 Wheel kit ASC-203 Aerosol can: TurboBlue

All measurements are actual figures taken from real-time testing using stated inputs, free from any filtering or weighting. Therefore, actual figures may significantly exceed that of other manufacturers with higher published weighted ratings.

Notes

¹ Due to the tolerances of birch plywood, dimensions may vary by ±3mm (1/8").

² Measured on axis, using a swept sine-wave input, in half-space environment.

³ Average over stated bandwidth. Measured in a half-space environment at 5 watts / 3 meters, then scaled to represent 1 watt / 1 meter, using a swept sine-wave input.

⁴ Unweighted diode-clipped pink noise. Measured in a half-space environment at 3 meters, then scaled to represent 1 meter.

⁵ Verified by subjective listening tests of familiar program material, before the onset or perceived signal degradation.

⁶ Optional black.

TECHNICAL SPECIFICATIONS

**TSE-118
FREQUENCY RESPONSE;
SENSITIVITY & HARMONIC
DISTORTION**

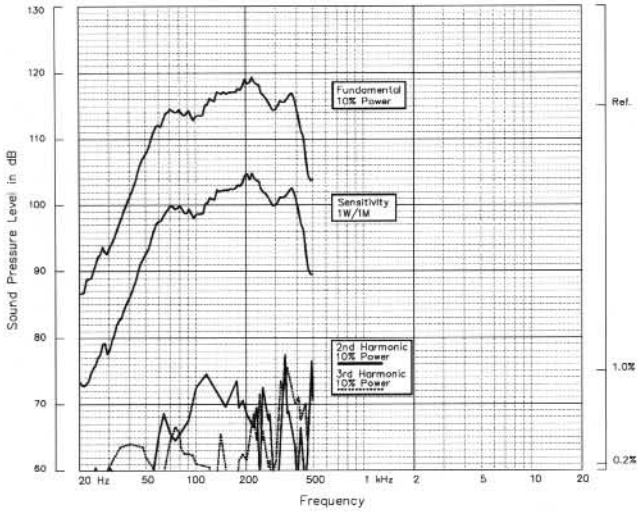

**TSE-218
FREQUENCY RESPONSE;
SENSITIVITY & HARMONIC
DISTORTION**

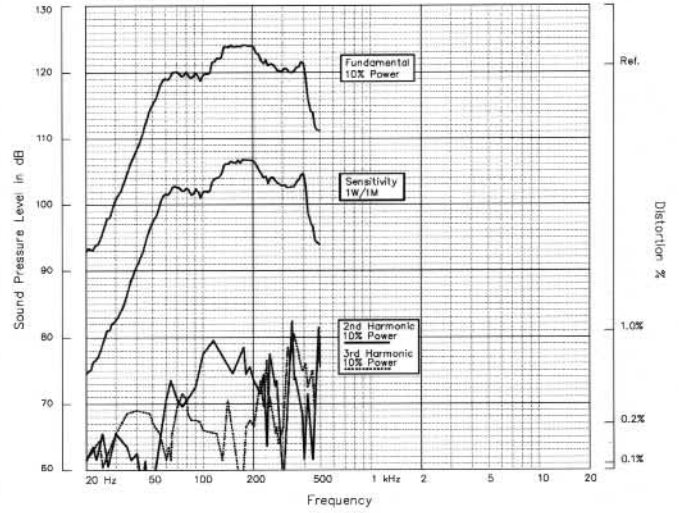

**TSE-118
IMPEDANCE**

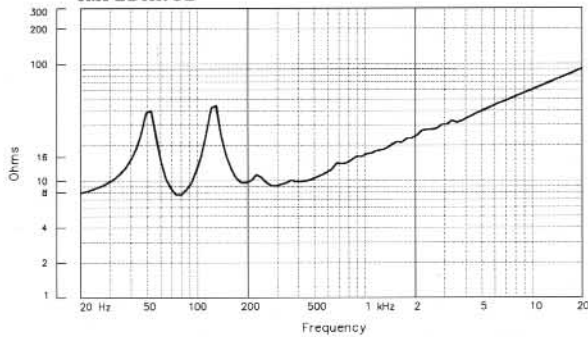

**TSE-218
IMPEDANCE**

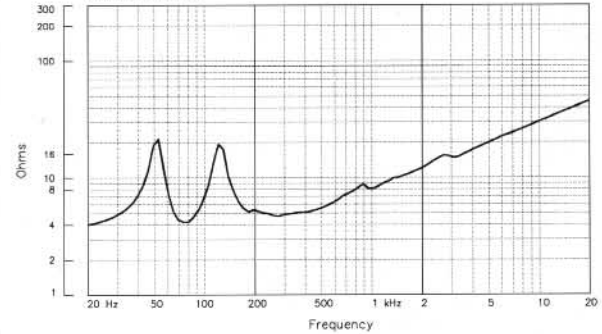

Notes on Measurement Conditions

Impedance

A common method, constant current circuit was used to measure the impedance.

Frequency Response

The frequency response shown was obtained by feeding a swept sine-wave through the system in a half-space environment. The position of the microphone was vertically on-axis, horizontally in-line with the MF/HF section at a distance of 3 meters, then scaled to represent 1 meter.

2nd & 3rd Harmonic Distortion

Distortion measurements were obtained using a Brüel & Kjær harmonic distortion analysis system and comply with AES recommendations for enclosure measurement (AES Paper reference: ANSI S4-26-1984).

Data Conversion

All graphs are digitally generated using the APEX custom software system, designed to translate data derived from Brüel & Kjær and Audio Precision "System One" test equipment into AutoCAD™. This program enables graphical information to be plotted to an accuracy of more than four decimal places.

FLYING AND LIFTING

A complete flying and arraying system is available for the TSE Series of enclosures. This has been designed to facilitate rapid installation and orientation. All the components are fully load-tested¹, certified and available as stock items.

A range of fixing hardware allows the TSE-118 to be installed from a variety of locations giving considerable freedom in the selection of optimum loudspeaker sites. All the components are manufactured from high-grade steel and finished with a black powder-coat.

FF-118 Flying Frame

The FF-118 flying frame fits around the TSE-118 and is secured to pre-drilled and threaded points. This allows the enclosure to be suspended from wires or chains to the desired position. The FF-118 is also used when the TSE-118 is to be incorporated into arrays or clusters. (Refer to section covering clusters and arrays.)

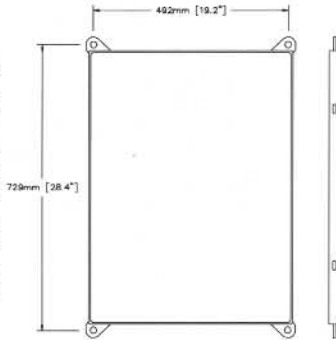

PA-111 Pole Kit Assembly

The PA-111 pole kit is designed to mount the TSE-111 above a TSE-118 or TSE-218 bass enclosure, raising the TSE-111 to 2 meters from ground level.

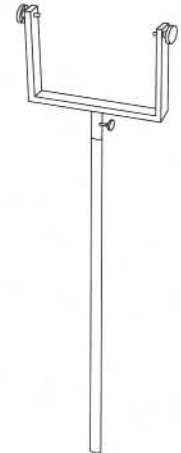

Notes

- ¹ UK Government. Individual certification available.
- ² Other colours to order.

Clusters and Arrays

The system for clustering and arraying the TSE Series of enclosures is made up of a dedicated amalgam of modular flying hardware. It allows the creation of simple 90° arrays, through to complex 360° circular clusters. The hardware automatically positions the enclosures at the correct horizontal increment to correspond to their optimum dispersion characteristics and to align them at the virtual point-source. (See fig 1)

When TSE-118 enclosures are incorporated in the cluster, it may be desirable to lock them together. This is accomplished using the BB-118 bracing bracket which is secured using the wheel bolt holes on the rear of the enclosure.

Each array or cluster requires different quantities of hardware depending on the application. The main flying-bar is divided into 90° sections. Each will fly 3 columns of TSE enclosures. The addition of wing-plates (WP-15) increases this to 4 TSE enclosures.

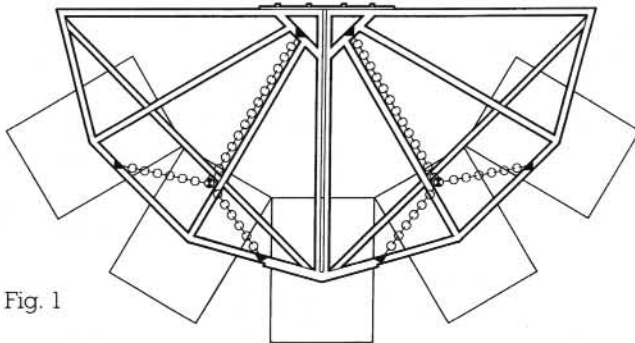

Fig. 1

Ordering Information

The FB-90C comprises the basic hardware to make up a 90°, 4 column cluster and includes the following components:

- 1 x FB-90 90° Flying quadrant (frame)
- 1 x CB-3 3-leg chain bridle used to support the flying quadrant
- 3 x HC-18 Hanging clamps to attach CB-3 to the FB-90
- 1 x SB-2 2-leg safety bridle
- 6 x EC-25 Enclosure clamps to attach flying frames
- 2 x WP-15 Wing plates
- All necessary high-tensile bolts

In addition to the FB-90C, the following components must be ordered to complete the cluster and will vary according to the particular cluster design:

- TS-6 6m Tilting strap
- TS-10 10m Tilting strap
- QL-75 Quick-links, 2 per enclosure.
- FF-118 Appropriate quantity and type of TSE flying frames, to suit cluster design.

For larger clusters (180°, 270°, and 360°) it is necessary to order multiples of the FB-90C. For example: a 270° cluster is made up from three FB-90C sets. These clusters require one additional component to lock the centres of the quadrants together. 180° clusters require a CS-180, 270° and 360° require a CS-360.

We recommend that you have your cluster and array designs verified to ensure that they are feasible and within the rated loading factors. Please contact your dealer for assistance or further information.

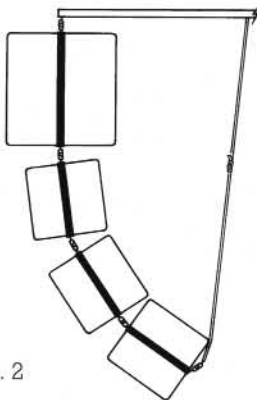

Fig. 2

Each enclosure, when fitted with a flying frame, simulates the link in a chain which forms the vertical column. The required vertical dispersion is set by adjusting a tilting strap attached between the lowest flying frame and the quadrant. One tilting strap is required for each vertical column and is available in 2 different lengths according to the amount of enclosures in each column. (See fig 2)

TSE - 118
ARCHITECTURAL & DESIGN
ENGINEERS SPECIFICATIONS

The loudspeaker shall be of the mono-amped, low-frequency type, consisting of one 457mm (18") low-frequency loudspeaker loaded with a patented TurboBass™ device.

Performance specifications of a typical production unit shall meet or exceed the following:

Frequency response, measured with a swept-sine wave input, shall be flat within ± 4 dB from 55 – 450Hz. Nominal impedance shall be 8 ohms. Power handling shall be 300 Watts RMS, 600 Watts program. Sensitivity measured with 1 Watt input at 1 meter distance on-axis, mean averaged over stated bandwidth, shall be 102 dB. Maximum SPL (Peak), measured with music program input at stated amplifier power, shall be 130dB.

Dimensions: 685mm H \times 503mm W \times 721mm D
 (26 $\frac{3}{4}$ "H \times 19 $\frac{3}{4}$ "W \times 28 $\frac{1}{4}$ "D)
 Weight: 40.25kg (90lbs)

Total enclosure volume shall not exceed 0.248 cu. meters (8 $\frac{3}{4}$ cu. ft.). The loudspeaker system shall be the Turbosound TSE-118. No other loudspeaker shall be acceptable unless submitted data from an independent test laboratory verify that the above combined performance/size specifications are equalled or exceeded.

A complete flying and arraying hardware system shall be available, comprising a range of load-certified components. The system shall be modular and have the facility of installing a single enclosure up to a 360° point-source array.

DIMENSIONS

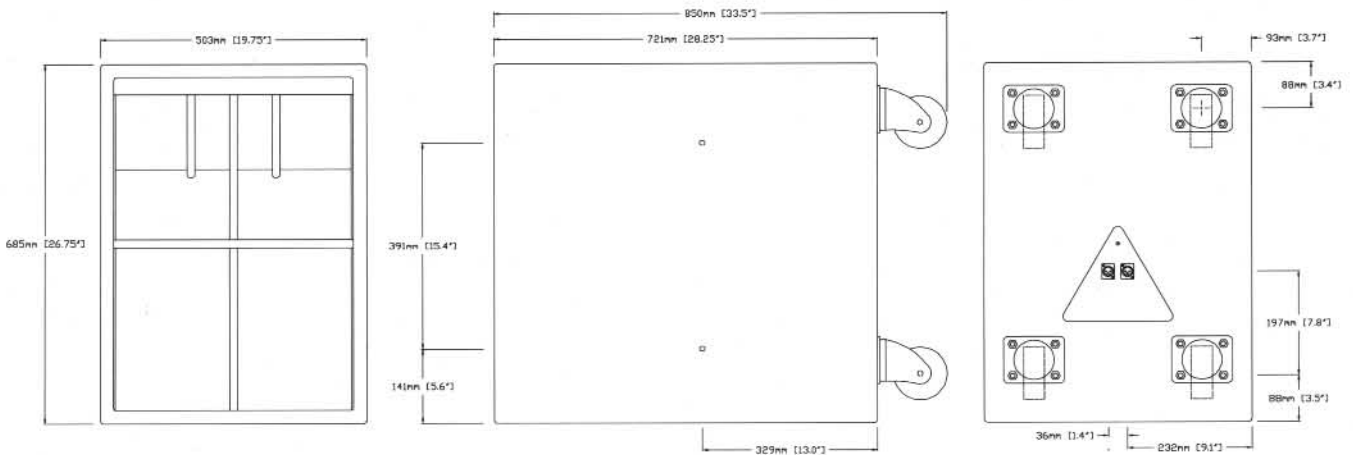

TSE-118

TSE - 218
ARCHITECTURAL & DESIGN
ENGINEERS SPECIFICATIONS

The loudspeaker shall be of the mono-amped, low-frequency type, consisting of two 457mm (18") low-frequency loudspeakers loaded with two patented TurboBass™ devices.

Performance specifications of a typical production unit shall meet or exceed the following:

Frequency response, measured with a swept-sine wave input, shall be flat within ± 4 dB from 50 - 450Hz. Nominal impedance shall be 4 ohms. Power handling shall be 600 Watts RMS, 1200 Watts Program. Sensitivity measured with 1 Watt input at 1 meter distance on-axis, mean averaged over stated bandwidth, shall be 105dB. Maximum SPL (Peak), measured with music program input at stated amplifier power, shall be 136dB.

Dimensions: 685mm H x 998mm W x 721mm D
 (26¾"H x 38¾"W x 28¼"D)
 Weight: 73kg (160 lbs)

Total enclosure volume shall not exceed 0.493 cu. meters (17⅞ cu. ft.). The loudspeaker system shall be the Turbosound TSE-218. No other loudspeaker shall be acceptable unless submitted data from an independent test laboratory verify that the above combined performance/size specifications are equalled or exceeded.

A complete flying and arraying hardware system shall be available, comprising a range of load-certified components. The system shall be modular and have the facility of installing a single enclosure up to a 360° point-source array.

DIMENSIONS

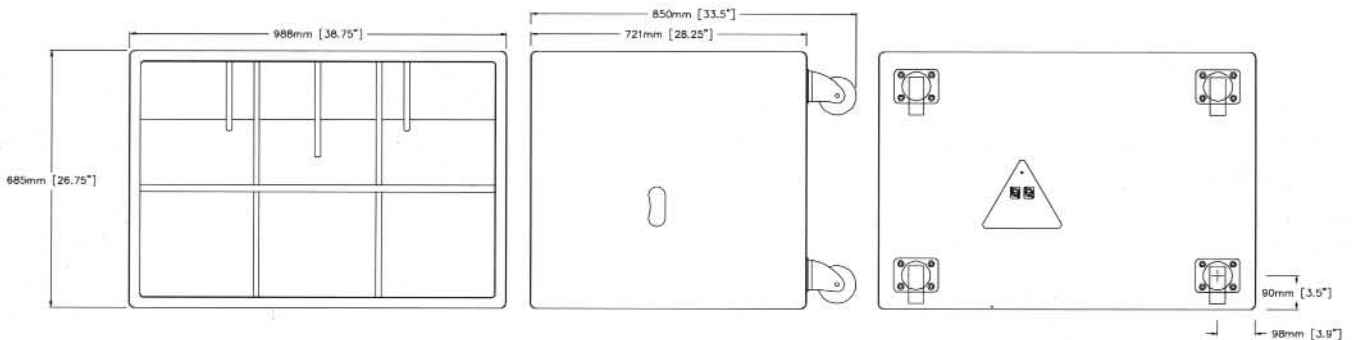

TSE-218

Dealer Stamp:

Turbosound™

An EdgeTech Company

Turbosound Limited

Star Road, Partridge Green

West Sussex RH13 8RY, England

Telephone: +44 (0) 403 711447

Facsimile: +44 (0) 403 710155

Turbosound operate a policy of continuous research and development. The implementation of new materials and/or production methods will always equal or exceed the published specifications which are subject to change without notice.

TURBOSOUND PATENT INFORMATION: TurboBass™ device; TurboMid™ device; V-Series devices (V-2™); Australia 515,535; Canada 1,076,033; Japan X11342/77; U.K. 1,592,246 1,598,310 & 3,614,434; U.S.A. 4,215,761 RE32,183 & 4,882,562; West Germany P274600/2. Worldwide patents pending on the TurboConcentric™ device. Other patents pending.

Printed in England. © Turbosound Ltd. 1990.
 Stock number: 00B003

TBOTEC03 - (Ver 2.2)